



MACAGI srl
benessere bambino

MODULO PONTE KEA
ARTICOLO

818PO
CODICE ARTICOLO

SCALA 1 : 80

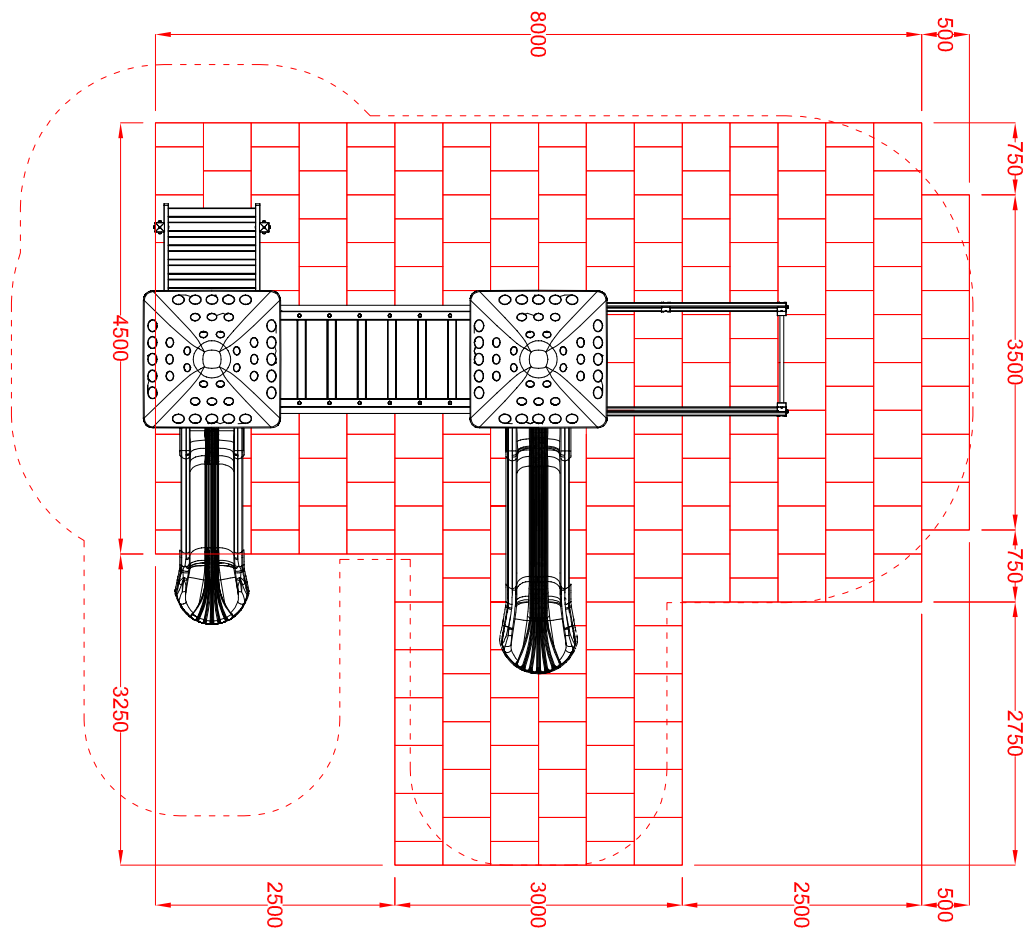
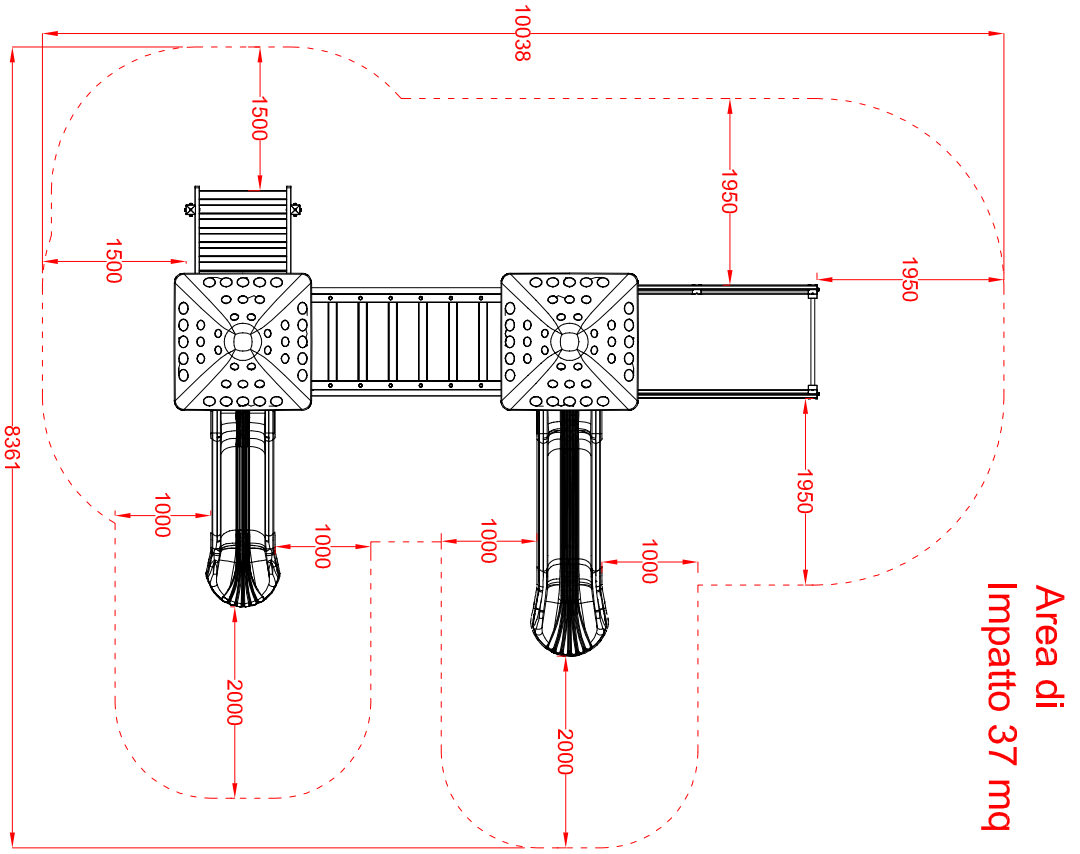

1	Quant. Pezzi	Figura	MODULO PONTE KEA: Area di impatto	Denominazione	Verniciato Acrilico	Finitura	818PO	Codice	Rev.
2	Revisione	19/10/2018	Data	Restyling articolo	Motivo	Cristian M.	Redatto	Verific. e Approvato	

≠	± 1 mm
∅	± 1 mm
↔	± 2 mm

Tolleranze Generali

Riferim. TAV